

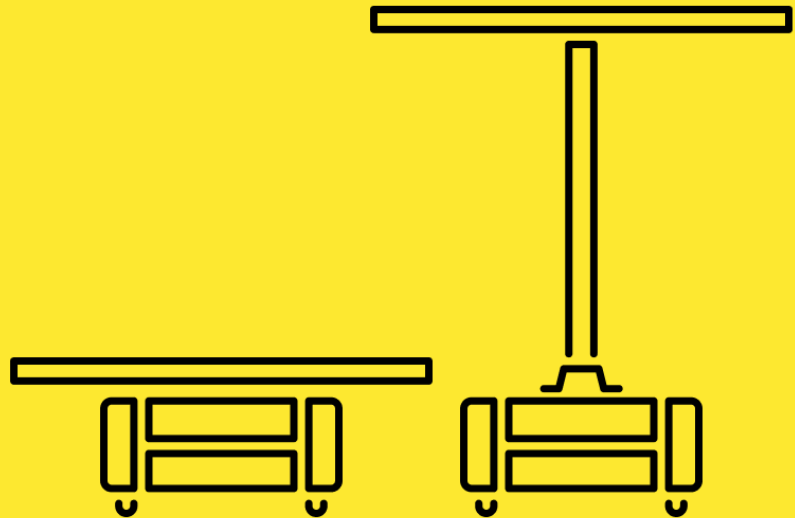

TURNTABLES G2

Orbitvu Turntable G2 is opening a totally new generation of Orbitvu turntables. Achieve unimaginable precision and shoot products like a pro player. Orbitvu Turntable G2 is designed to get the most out of a captured item and speed up the photography workflow.



IMAGING SOLUTIONS FOR VISUAL CONTENT PRODUCTION

With automated product photography, you can impress anyone with impeccably styled 360° spins, product videos, and still photos of small, medium, and maxi-sized products up to 250kg.

Just choose between the MIDI and MAXI size and enjoy all the benefits of highly responsive, software-controlled rotating platforms. Shoot your products with ease and provide your customers with engaging visual content.



PRECISION THAT COUNTS

Orbitvu Turntables G2, with their modern, robust design as well as strong and stable construction, are the preferred product for anyone looking for quality shots.

Orbitvu Turntables MIDI & MAXI G2 offer not only a solid construction but also great accuracy and repeatable positioning, no matter the type of visual content. Manage turntable positions and speeds conveniently from your computer. Light the scene with independently controlled external continuous or flash lamps and show various dimensions of a product. See precision in its realest form.



How does it work?

Start by scanning the unique product code. Our system will automatically assign it to output file names and link it with the product in your online store.

Next step? Export and publish the content online to multiple predefined locations!

Save valuable time while the process runs in the background. With the e-commerce plugins and automatic SKU linking, get the product online in less than a few minutes.

See how easy it is? And that's the beauty of our automated solutions - anyone can make stunning product photos after basic training!

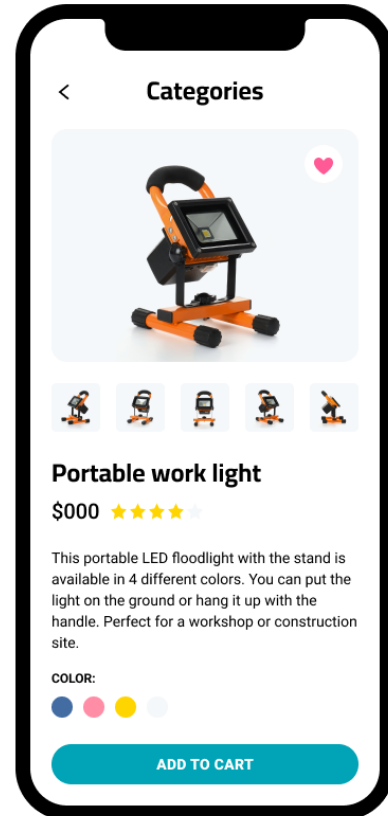

Scan the QR code and see the process yourself.



90 seconds per spin

Creating engaging content is now easier than ever! Automation allows you to capture a full product spin with 36 still images in less than two minutes. Dazzle your audience with the content they need to make more informed purchase decisions. Happy customers = fewer returns!



TURNTABLES G2 FAMILY

Orbitvu Turntable G2 is a rotating platform of robust and modern design. It comes in 2 sizes, MIDI and MAXI, to cater to the distinctive needs of our users. However, both are incredibly quiet at work, made of durable materials, and easy to assemble and level.

G2 means more precision & quiet engine operation

When developing the second generation of Orbitvu Turntables, we decided to focus on improving the quietness of the engine operation as well as the stability of the platforms. Choose the one you need and start creating 360° spins, product videos, and stills that your customers will love!



ORBITVU TURNTABLE MAXI G2

Orbitvu Turntable MAXI G2 is equipped with a 150cm platform supported by a stable construction. It is dedicated to users who work with products weighing up to 250kg. The MAXI G2 version features high-precision operation even with edge loading or asymmetrical products with a shifted center of gravity. It's the go-to choice for capturing museum collections, small furniture pieces, or big household equipment.



ORBITVU TURNTABLE MIDI G2

Orbitvu Turntable MIDI G2 is equipped with a 75cm diameter platform on a pole with a maximum load of up to 40 kg. It can also be conveniently installed on the desk if needed. Everything to make your workflow easier! The MIDI G2 version is a perfect choice for capturing artificial jewelry and watches, small electronic parts, shoes, accessories for animals, and cosmetics - the options are endless.



Capture 300 products a day

Scale up the content production with ease thanks to Orbitvu's streamlined workflow. With durable, highly responsive, software-controlled turntables, you can capture as many as 300 items per day and become the master of efficient 360° product photography.





Explore the device

MIDI G2

Orbitvu Turntable MIDI G2, with its stable construction and modern design, can be installed both on the floor and on the desk. It's up to you and your current needs how you're going to use it.

Thanks to independently controlled lights, flash, or continuous, you can bring out the details of the products and make more detail-oriented product photos.

"Using Orbitvu devices, we are able to digitize very diversified museum objects: from small ones such as jewelry and numismatic coins to medium-sized and even very big ones. Thanks to these solutions, we could at last start to digitize three-dimensional museum objects."

Slawomir Żabicki, Head of Digitization Studio of City Public Library

Consistency with custom templates

The bespoke software lets you store your workflow settings - from shooting, through post-production, to publication - so you can repeat the same setup and easily create consistent, quality content.

Software-controlled hardware

Orbitvu Station makes your computer the control hub. Whether adjusting your camera or preprogramming turntable angles, you can do all of it conveniently from your laptop.



MOTORIZED TURNTABLE automatically positions your products at desired angles for packshots and allows you to create 360° spins with a single click.



Shoot products up to 250 kg

Capture outstanding product content of objects even up to 120cm wide. Even the largest and heaviest products are no longer challenging, thanks to the platform's stable construction and edge load in the MAX! G2 version. Spin the products and present products from different angles!



Scan the QR code and see how the 360° spin works.



Explore the device

MAXI G2

The MAXI G2 version gives you high-precision operation even with edge loading or asymmetrical products with a shifted center of gravity. It's all about the increased stability of the base when inserting heavy products onto the platform. As a result, even items up to 250kg won't outweigh the platform. It's staying steady at all times.

Additionally, the support wheels allow the machine to operate freely in both directions. This feature will provide you with the flexibility to capture the angle when the light is best and show the dimensions of the product.

Orbitvu allowed us to react quicker, move faster, and do a lot more photos in a given day than we'd ever done in the past.

Kent Fleming, Director of Media Services, PureRED

Multi-destination publishing

Publish your content directly to your online store, or easily export it for any other purpose, such as print or marketing. The process runs seamlessly in the background without taking any of your valuable time.

Automatic post-production

Post-production is a breeze thanks to our software automation, with functions ranging from basic editing tools to innovative solutions.



The solid construction of the platform gives you the stability you need when shooting heavy products, while the support wheels allow the device to operate freely in both directions.

Accessories overview

With optional accessories, Orbitvu Turntable G2 can be truly tailored to suit your products & workstyle. And you can be assured we are developing new accessories as you read these lines.

For the complete list of accessories and help choosing the best ones, feel free to contact our global sales force at orbitvu.com/contact.



OPERATOR STAND

Enjoy the comfort and convenience of an ergonomic operator stand.



COLUMN STAND

A professional integrated stand ensures flawless camera positioning.



ORBITVU TURNTABLES G2 Family comparison

With Orbitvu Turntable G2, it's not that any model is better than the other; both of them are carefully designed to serve their purpose. This comparison might help you decide which option is the one for you. If not, contact our worldwide sales force through orbitvu.com/contact.

TURNTABLE MIDI G2

Order Code 211H1-TT1

Orbitvu Turntable MIDI G2 is a rotating platform of a new generation for small and medium-sized products. With modern design and stable construction, the product is ideal for capturing detailed 360° spins.

Motorised Turntable Diameter	75 cm / 29.5 in
Minimum Rotation Step	1°
Max Load	40 kg / 53.1 lb (with column) 150kg / 331 lb (without column)
Max size of photographed item	40×40×60 cm / 15.7×15.7×23.6 in
Power Supply	100 - 230VAC
Weight Net	25,5 kg / 56.2 lb (with column) 24,1kg / 53.1 lb (without column)
Power Consumption	max. 200W

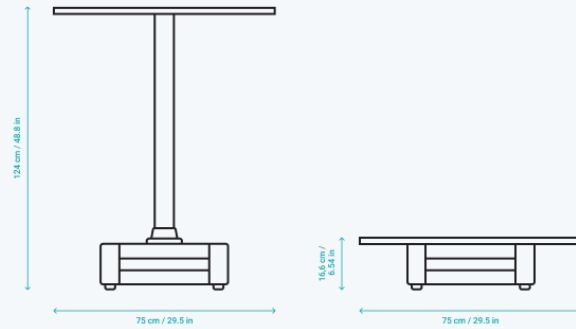



TURNTABLE MAXI G2

Order Code 211H1-TT2

Orbitvu Turntable MAXI G2 is a rotating platform of the new generation designed for big and heavy products. With modern design and stable construction, the product is ideal for capturing detailed 360° spins.

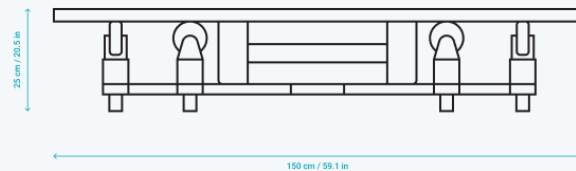
Motorised Turntable Diameter	150 cm / 59.1 in
Minimum Rotation Step	1°
Max Load	250 kg / 551 lb
Max size of photographed item	100×100×130 cm / 39.4×39.4×51.2 in
Power Supply	100 - 230VAC
Weight Net	42 kg / 92.6 lb
Power Consumption	max. 200W



Categories 

[View all](#) [Trainers](#) [Boots](#) [Sandals](#) [Sandals](#)

Sneakers
BLACK HIGH TOP 







Sneakers
LOW TOP







Popular now

Sneakers
White Shoes 



White, gold-tone sneakers, perfect for day-to-day activities.

[Back to Products](#)





Blue high top shoes

\$000 

This distinctive, water-repellent footwear is a perfect choice for winter. This version comes in a rainbow-stripe design.

COLOR:



ADD TO CART

[Back to Products](#)

BLACK HIGH TOP





Automatic content-to-product linking

SKU can be matched with a field in your e-shop product configuration. This will create an automatic link that will allow you to quickly upload content to your site.

SOFTWARE

Orbitvu's software is made for easier product content production and delivery. From an image capture workstation all the way to the e-shop product page, our software automates tedious tasks and is open to integration with external tools and systems.



"It actually turns out that the Orbitvu software is incredibly intuitive and very easy to use. I was up and running in about 30 minutes shooting, and I found it very comfortable and very familiar."

Francis Hills, Photographer

Orbitvu Station

Orbitvu Station is our product photography studio software. It allows you to get content online quickly and effortlessly, thanks to a fully controlled turntable and camera. The software automatically does image post-production and lets you publish to multiple locations for any purpose. It's also a 360-degree product photography and video editing tool.

Camera compatibility: **Canon DSLR and mirrorless***

Software compatibility: **Mac OS X or Windows**

Output 360° format: **HTML5, animated GIF, MP4, MOV**

Output video format: **MOV, MP4, animated GIF**

Output image format: **png, jpeg, WebP, tiff, bmp and other via external action**

* For more information, visit our compatibility page: orbitvu.com/compatibility-guide

Orbitvu SUN Cloud

Orbitvu SUN Cloud is a SaaS cloud platform that enables you to seamlessly manage, share, and distribute your product content. It allows you to easily create product tours that combine high-quality 360° spins with hotspots, images, and videos. Think of it as a product-oriented DAM on steroids.

Orbitvu e-commerce plugins

E-commerce plugins allow you to get product content automatically delivered to your e-shop. SKU matching can be done automatically or manually in batches with two types of plugins: for content self-hosted on your e-shop and for content hosted in Orbitvu SUN Cloud. It includes plugins like Shopify, Magento, Shopware, and many others.



Still



360°



Videos



Product tours



ABOUT US

Our photography adventure started over 20 years ago. We set off just when the birth of digital photography and e-commerce created new needs and exciting possibilities to showcase products online.

Digital content production creates the need for consistent, good-quality images produced in a short time and at a reasonable cost. Traditional photography and manual post-production may yield high-quality results but stay slow, complicated, and expensive.

Orbitvu takes the best from traditional photography and combines it with advanced software and hardware innovations. We automate and optimize digital content production. We help to deliver it online and effectively share in your sales and marketing activities.

As an international leader in the automated photography market, we work for you in a team of more than 150 employees worldwide, with our own research & development and 4000 square meters of Europe-based production spaces. Our carefully perfected solutions will cover all of your workflows, improve the online product experience of your customers, and effectively reduce expenditure.

With Orbitvu, your products are teleported to your customers.

WHY ORBITVU?

Our roots are in professional studio photography and software engineering. Over the past years, we have managed to combine them into photo automation products that offer the best of both worlds: professional image quality and top software performance.

Our team of over 20 engineers develops our technology and products 100% from scratch. We believe in an open and direct business relationship. What you see is what you get. Our devices have no remote server locking or hidden fees. We are the largest photo automation manufacturer in the world, backed by venture capital with a long-term product development strategy and solid cash flow re-invested in R&D.



HOW IT WORKS



Scan the
barcode



Place the
product



Set the
scene



Capture
product



Edit
photos



Publish
content



WWW.ORBITVU.COM